

Product Introduction

01. Product Diagram

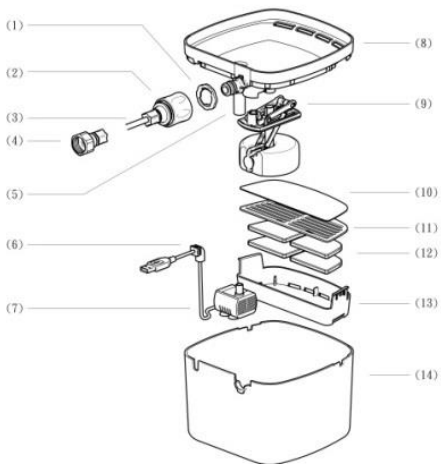

- (1) Lock ring (prevent the Lid be opened by Pets)
- (2) Quick connector with water stop
- (3) NSF LLDPE tube 10 meter length
- (4) 1/2 inch Female threaded Faucet connector
- (5) Pump's water tube
- (6) USB cable holder
- (7) Water Pump with 2 meter USB cable
- (8) Fountain Lid
- (9) Automatic water filler
- (10) High-density filter cotton
- (11) Filter Shelf
- (12) Sodium-free Ion Exchange Resin x 2 bags
Natural Coconut Shell Activated Carbon x 2 bags
- (13) Filter Box
- (14) Water Tank